

H-HMB系列/H-HMB Series

产品特点 / Product Feature

H-HMB系列液压马达在吸取了国内外曲轴连杆式液压马达静压平衡优点的基础上，经过不断试验、改进、提高而成。该系列马达壳体强度高，内部动态元件承载能力大。由于采用静压平衡的形式，减少了内部摩擦力，因此减少了热量产生以及与此相关的负面效应。

其主要特点如下：

- 由于柱塞、连杆、偏心套设计成静压平衡，减少了连杆与偏心套的摩擦力及柱塞体的侧向力，降低了球铰副的接触比压，这些均减少了传动过程中的摩擦损失。因而EHMB系列液压马达具有高的机械效率及高的起动扭矩（起动时的机械效率0.90以上）的特点；
- 采用静压平衡技术的轴配流器，防止了配流器的倾斜，密封性能好，泄漏少，可在高压（最高压力可达29MPa）下进行连续工作；
- 密封环采用特殊材料及结构，减少了泄漏，提高了容积效率；
- 马达的主要传动件采用特殊材料和先进的热处理工艺，提高了整体使用寿命；
- 该系列马达的外形及安装尺寸与原装Staffa基本相同，性能参数与原装Staffa相近，是替代进口Staffa马达的理想选择。

由于H-HMB系列液压马达具有上述一系列特点，因而可广泛应用于塑料机械、船舶甲板机械、矿山建筑工程机械、起重运输设备、重型冶金机械、石油煤矿机械、机床、轻工设备、钻机等各种机械的液压传动系统中，特别用于注塑机的螺杆驱动、提升绞盘、卷筒的驱动、各种回转机械的驱动等传动机械中。

H-HMB series' hydraulic motor is the achievement of our year's experience of hydrostatic balance technology. It features with higher intensity of casing and larger carrying capacity of internal dynamic components. Reduced internal friction, heat, and all negative effects are realized by hydrostatic balance technology.

Main Characteristics:

- The hydrostatic balance built between the piston, con-rod and eccentric sets reduces the friction between con-rod and eccentric sets, and also reduce the lateral friction on pistons, and contact pressure on ball the socket, thus to reduce the friction loss while on load. With above, EHMB series' motor features with high mechanical efficiency and starting torque (The Mechanical efficiency while starting is up to 90%);
- Hydrostatic balance shaft distributor prevents the shaft from tilting, thus to get excellent sealing, less leakage, and continuous running under high pressure(Max.pressure reaches to 29Mpa);
- Special materials and structure of seals reduce the leakage and improve the volumetric efficiency;
- Special materials and advanced treatment on main driving parts prolong the overall service life;
- Ideal replacement of STAFFA motor with interchangeable mounting and performance.

H-HMB series' motor is widely applied in all kinds of hydraulic transmission systems, such as plastic injection molding machines, deck machinery, construction machinery, hoist, transport vehicle, heavy metallurgical machinery, petroleum & mining machinery, light industrial equipments, drilling machinery, and so on.

HFM

HGM

QJM

H-HMB

H-HMC

HCA

HCB

HMS

HA6V

HA2F

H-HMB系列/H-HMB Series

产品标识说明 / Ordering Code

****_****_****_****_****_*****

1 2 3 4 5 6

1) H-HMB(HD)液压马达代号/ Model-H-HMB (HD)

H-HMB为标准马达/H-HMB-Standard Motor

H-HMBHD为重载马达/H-HMBHD-Heavy Duty Motor

2) 型号/Type

3) 名义排量/Nominal Displacement

4) 输出轴形式/Shaft Options

a、P表示为平键轴 P - Parallel Keyed Shaft

b、T表示为锥轴 T - Taper Keyed Shaft

c、S表示为外花键轴 S - Spline Shaft

d、Q表示为内花键轴 Q - Female Spline Shaft

5) 进油口的形式/Distributor

6) 其它设计参数/Others

型号举例 / Example

| | | | | | |
|-------|-----|------|-----|-----|----|
| H-HMB | 270 | 4300 | P71 | F03 | ** |
|-------|-----|------|-----|-----|----|

马达代号/ Model H-HMB (HD)

型号/ Type 270

排量/ Displacement 4300ml/r

轴/ Shaft P71

油口/ Distributor F03

其他/ Others

H-HMB系列/H-HMB Series

技术参数 / Technical Specification

| 型号 Model | 理论排量 Theory Displacement | 压力/Pressure | | 扭矩/Torque | | 最高转速 Max. Speed | 额定功率 Rated Power | 重量 Weight |
|---------------|--------------------------------|------------------------|-----------------------|----------------------|---------------------|--------------------|---------------------|--------------|
| | | 额定压力 Rated Pressure | 尖峰压力 Max. Pressure | 额定扭矩 Rated Torque | 单位扭矩 Unit Torque | | | |
| | | ml/r | Mpa | Mpa | N.m | | | |
| H-HMB080-1000 | 988 | 23 | 29 | 3324 | 145 | 300 | 90 | 144 |
| H-HMB080-1100 | 1088 | 23 | 29 | 3661 | 159 | 300 | 90 | |
| H-HMB080-1250 | 1237 | 23 | 29 | 4162 | 181 | 280 | 90 | |
| H-HMB080-1400 | 1385 | 23 | 29 | 4660 | 203 | 260 | 100 | |
| H-HMB100-1600 | 1630 | 23 | 29 | 5484 | 238 | 240 | 100 | 144 |
| H-HMB125-1400 | 1459 | 23 | 29 | 4909 | 213 | 300 | 95 | 235 |
| H-HMB125-1600 | 1621 | 23 | 29 | 5454 | 237 | 270 | 95 | |
| H-HMB125-1800 | 1864 | 23 | 29 | 6271 | 273 | 235 | 95 | |
| H-HMB125-2000 | 2050 | 23 | 29 | 6820 | 297 | 220 | 95 | |
| H-HMB200-2400 | 2432 | 23 | 29 | 8182 | 356 | 220 | 120 | 285 |
| H-HMB200-2800 | 2757 | 23 | 29 | 9276 | 403 | 195 | 120 | |
| H-HMB200-3100 | 3080 | 23 | 29 | 10362 | 451 | 175 | 120 | |
| H-HMB270-3300 | 3291 | 23 | 29 | 11072 | 481 | 160 | 130 | |
| H-HMB270-3600 | 3575 | 23 | 29 | 12028 | 523 | 145 | 130 | 420 |
| H-HMB270-4000 | 3973 | 23 | 29 | 13367 | 581 | 130 | 130 | |
| H-HMB270-4300 | 4313 | 23 | 29 | 14511 | 631 | 120 | 130 | |
| H-HMB325-4500 | 4538 | 23 | 29 | 15268 | 664 | 115 | 130 | |
| H-HMB325-5000 | 4992 | 23 | 29 | 16795 | 730 | 105 | 130 | 430 |
| H-HMB325-5400 | 5310 | 23 | 29 | 17865 | 777 | 100 | 130 | |
| H-HMB400-5500 | 5510 | 23 | 29 | 18135 | 788 | 120 | 175 | |
| H-HMB400-6000 | 5996 | 23 | 29 | 19735 | 858 | 120 | 175 | 495 |
| H-HMB400-6500 | 6483 | 23 | 29 | 21337 | 928 | 120 | 175 | |
| H-HMB400-6800 | 6807 | 23 | 29 | 22404 | 974 | 120 | 175 | |

HFM

HGM

QJM

H-HMB

H-HMC

HCA

HCB

HMS

HA6V

HA2F

H-HMB080/100系列/H-HMB080/100 Series

H-HMB080 外形及安装尺寸/ H-HMB080 Installation Dimensions

进油口为F01的安装尺寸/With F01 Distributor

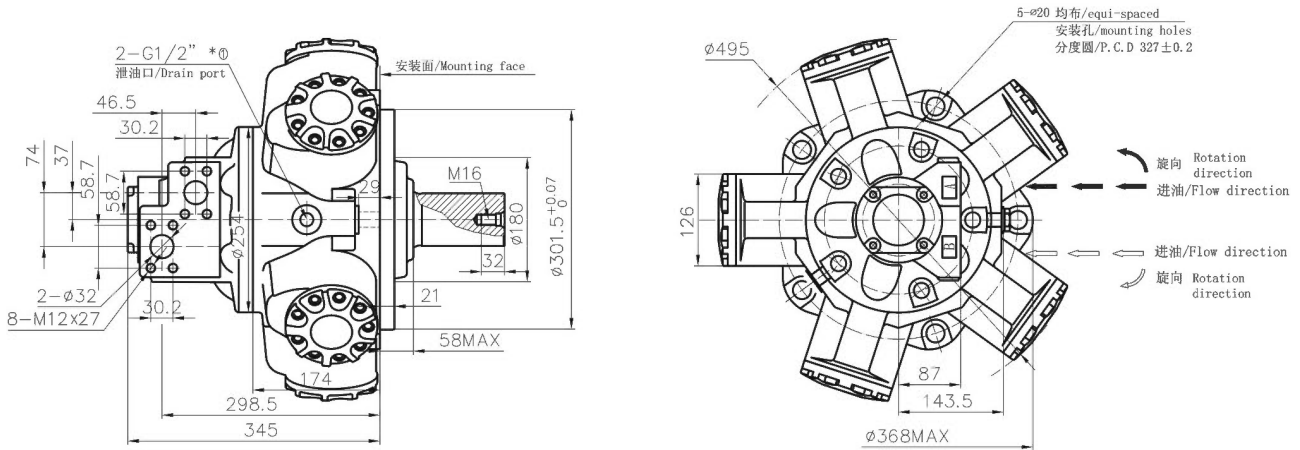

*①可选项UNF3/4"-16接头/Option:UNF3/4"-16

H-HMB100 外形及安装尺寸/ H-HMB100 Installation Dimensions

进油口为F01的安装尺寸/With F01 Distributor

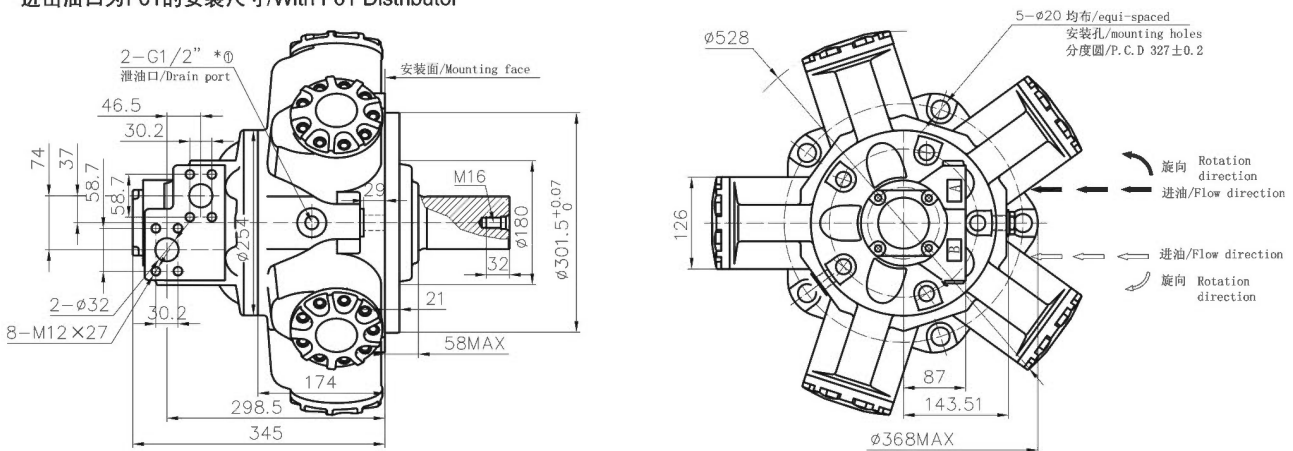

*①可选项UNF3/4"-16接头/Option:UNF3/4"-16

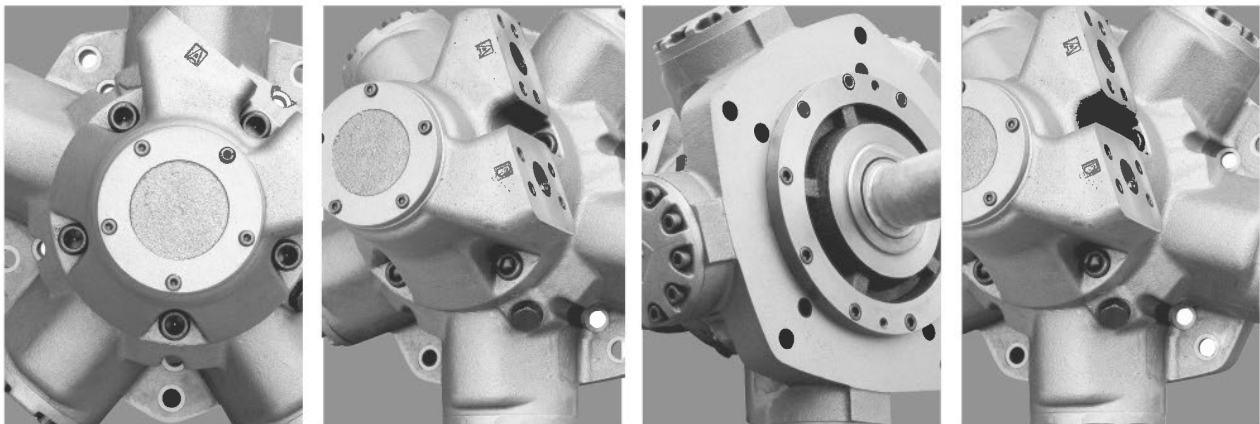

H-HMB080/100系列/H-HMB080/100 Series

H-HMB080/H-HMB100-P72*

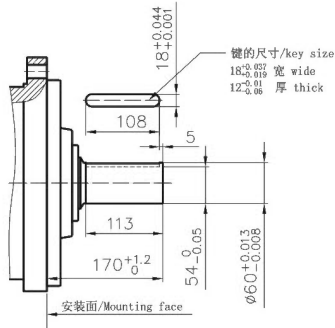

H-HMB/H-HMB100-S71*&S72*

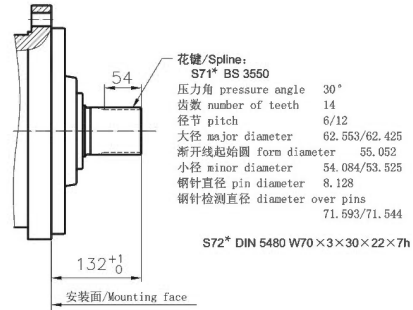

H-HMB080/H-HMB100-T71

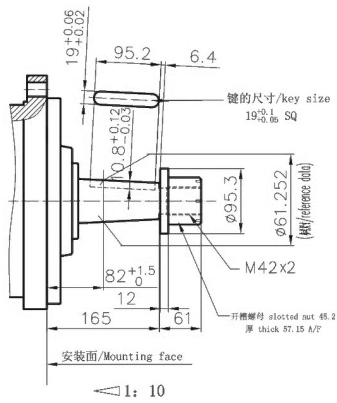

H-HMB080/H-HMB100-Q71

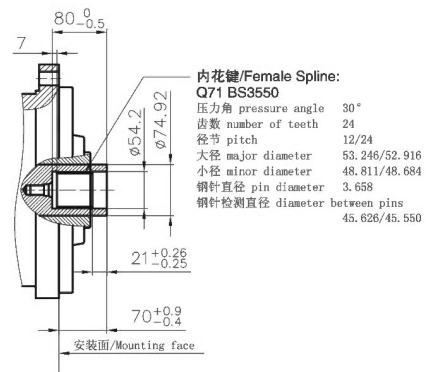

H-HMB080/H-HMB100-P71

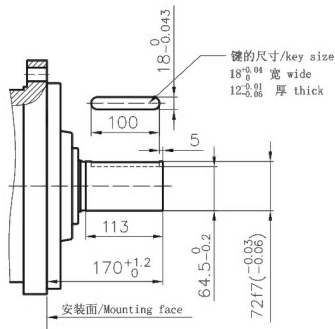

注释：右上角带*的轴为标准轴
 如：P72* 为标准平键轴 S71* 为标准花键轴

Notes: Shaft model with "*" is the standard shaft
 Example: P72*=Standard Parallel Keyed Shaft
 S71*=Standard Spline Shaft

HFM

HGM

QJM

H-HMB

H-HMC

HCA

HCB

HMS

HA6V

HA2F

H-HMB080/100系列/H-HMB080/100 Series

H-HMB080/100 外形及安装尺寸/H-HMB080/100 Installation Dimensions

进出油口为F01B的安装尺寸/F01B Distributor

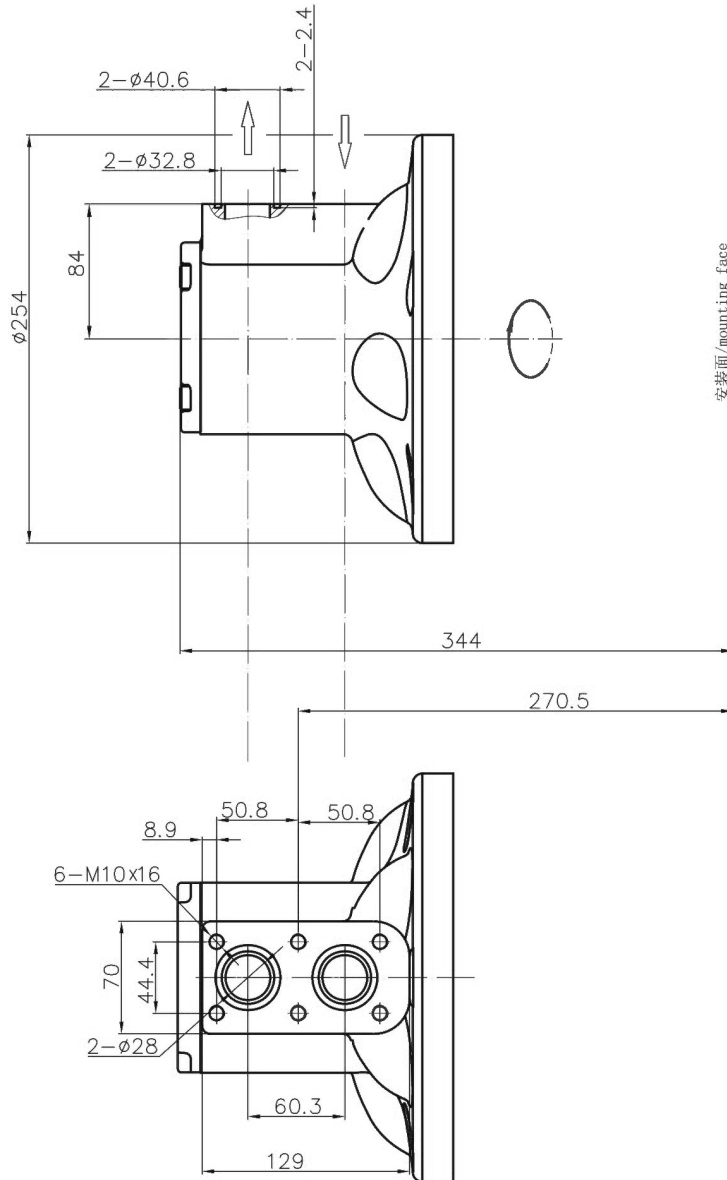

H-HMB(HD)125系列/H-HMB(HD)125 Series

H-HMB(HD)125 外形及安装尺寸/H-HMB(HD)125 Installation Dimensions

进出油口为F01的安装尺寸/With F01 Distributor

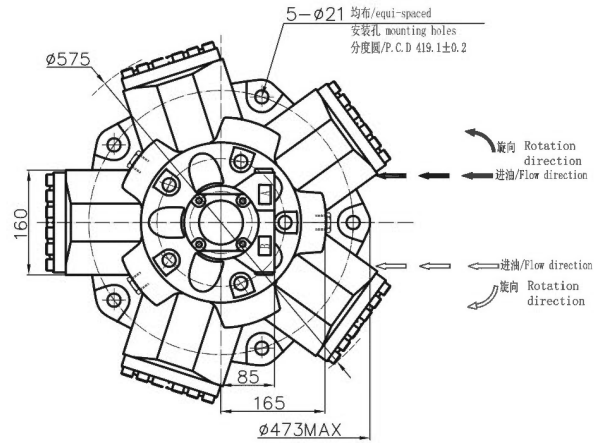
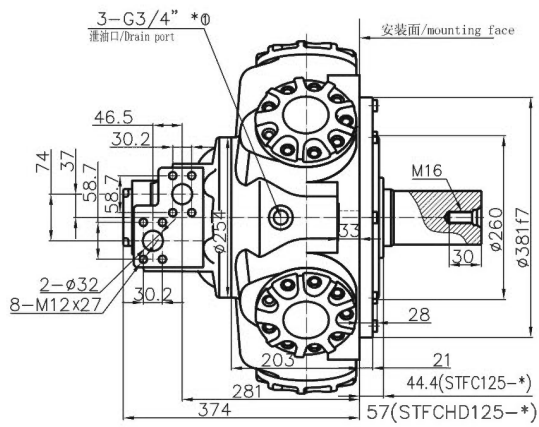

*①可选配UNF3/4"-16接头/Option: UNF3/4"-16

H-HMB125-P72

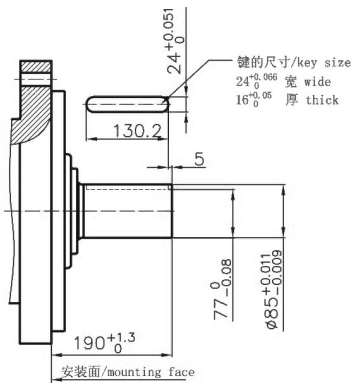

H-HMB125-P73*

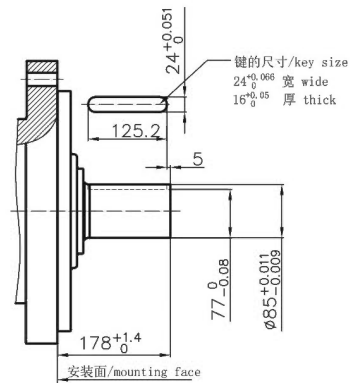

H-HMB125-P74

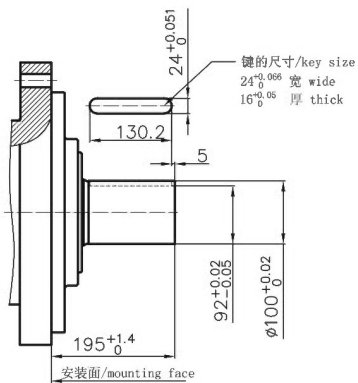

H-HMB125-T71

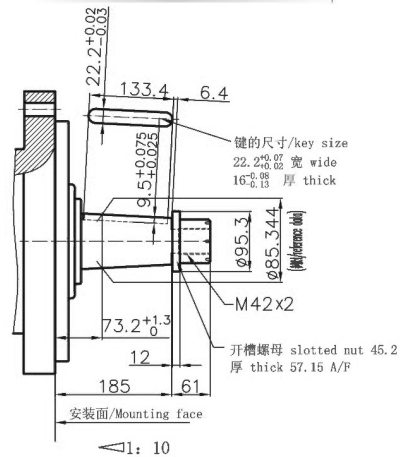

∠1: 10

HFM

HGM

QJM

H-HMB

H-HMC

HCA

HCB

HMS

HA6V

HA2F

H-HMB(HD)125系列/H-HMB(HD)125 Series

H-HMBHD125-T72

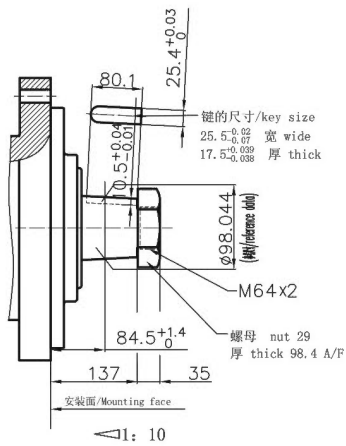

H-HMBHD125-T73

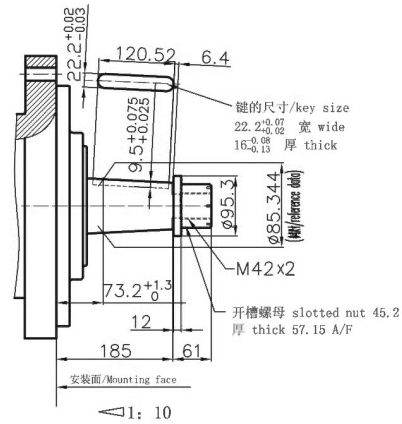

H-HMB125-S71* & 72*

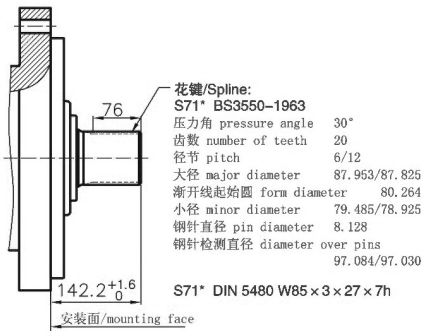

H-HMB125-S73 & 74

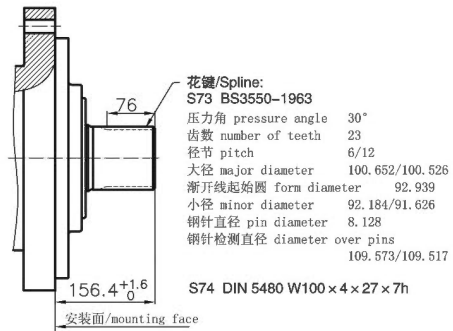

H-HMBHD125-Q71

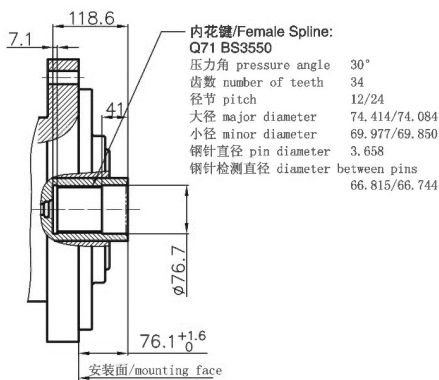

H-HMB125-P71

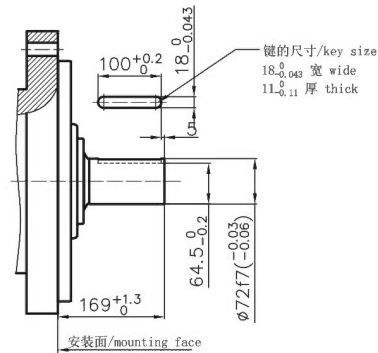

注释：右上角带*的轴为标准轴
 如：P73* 为标准平键轴 S71* 为标准花键轴

Notes: Shaft model with "*" is the standard shaft
 Example: P73*=Standard Parallel Keyed Shaft
 S71*=Standard Spline Shaft

H-HMB(HD)125系列/H-HMB(HD)125 Series

H-HMB(HD)125 外形及安装尺寸 / H-HMB(HD)125 Installation Dimensions

进出油口为F02的安装尺寸 / F02 Distributor

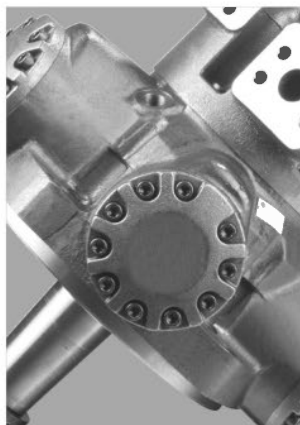
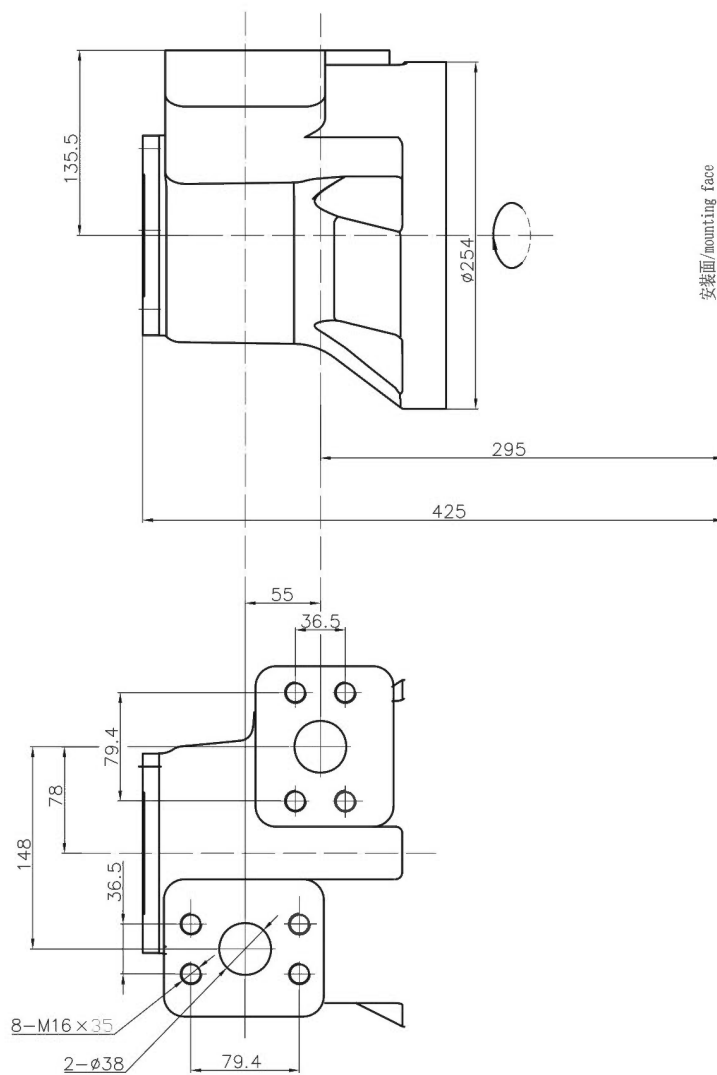

HFM

HGM

QJM

H-HMB

H-HMC

HCA

HCB

HMS

HA6V

HA2F

H-HMB(HD)125系列/H-HMB(HD)125 Series

H-HMB(HD)125 外形及安装尺寸/ H-HMB(HD)125 Installation Dimensions

进出油口为F01B的安装尺寸/ F01B Distributor

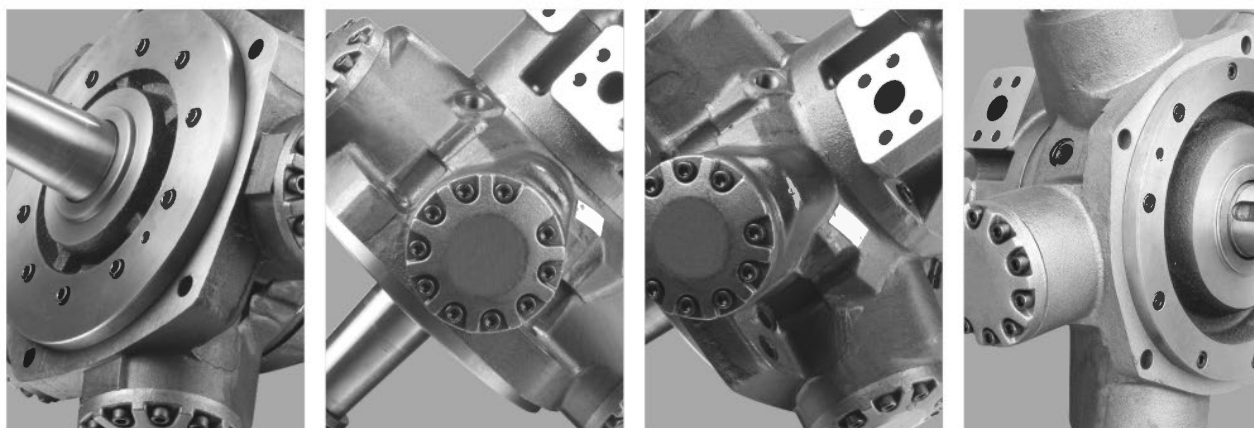
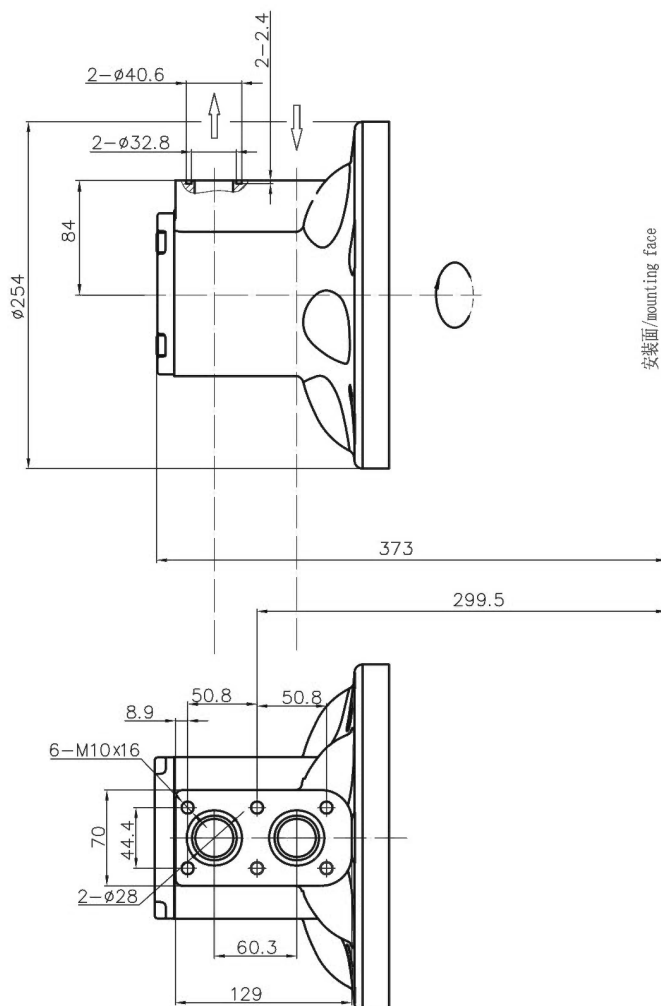

H-HMB(HD)125系列/H-HMB(HD)125 Series

H-HMB(HD)125 外形及安装尺寸 / H-HMB(HD)125 Installation Dimensions

进出油口为F02B的安装尺寸 / F02B Distributor

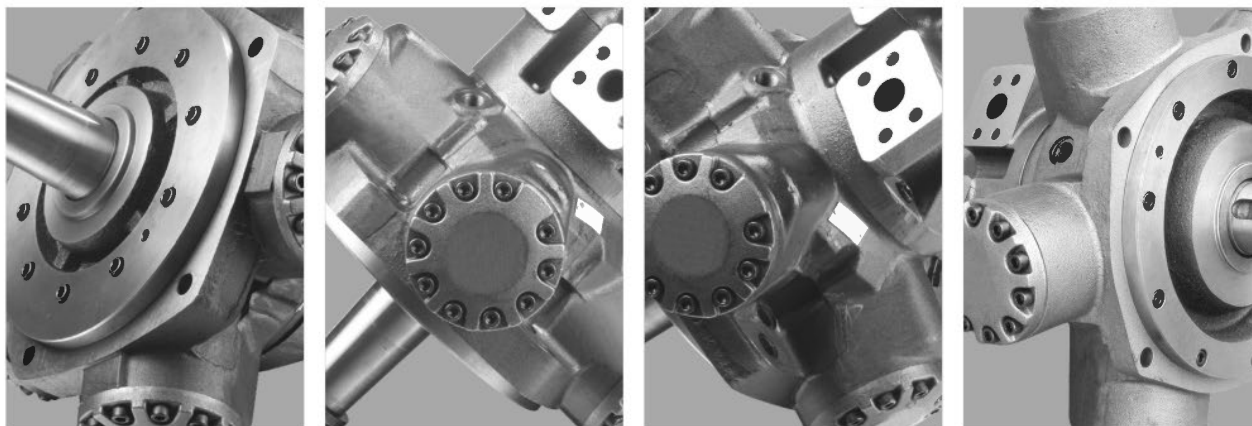
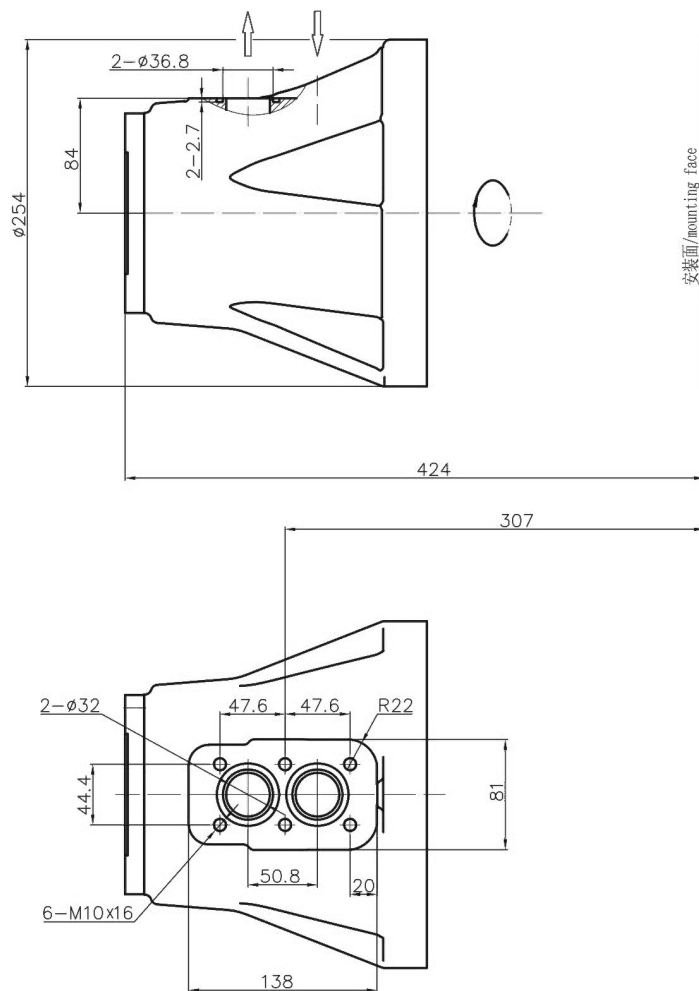

HFM

HGM

QJM

H-HMB

H-HMC

HCA

HCB

HMS

HA6V

HA2F

H-HMB(HD)200系列/H-HMB(HD)200 Series

H-HMB(HD)200 外形及安装尺寸/ H-HMB(HD)200 Installation Dimensions

进出油口为F02的安装尺寸/With F02 Distributor

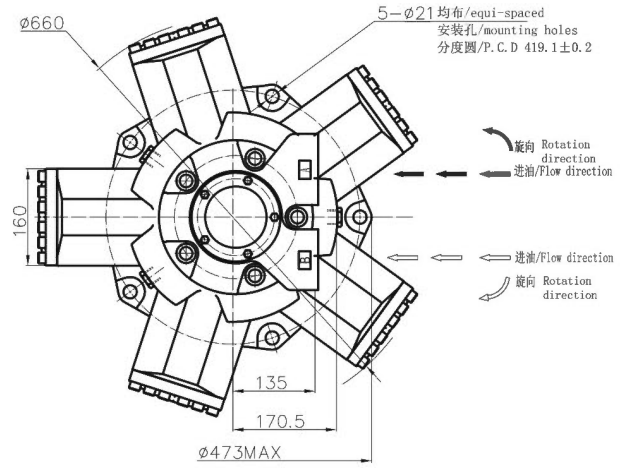
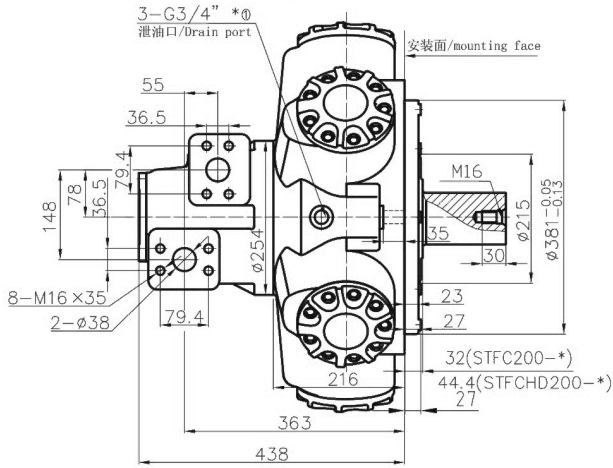

*①可选配UNF3/4"-16接头/Option: UNF3/4"-16

H-HMB200-P71

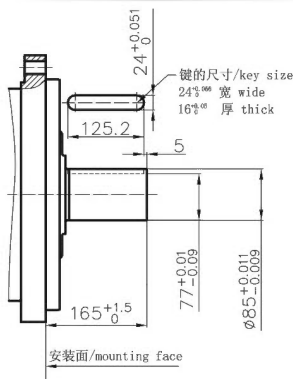

H-HMBHD200-P73*

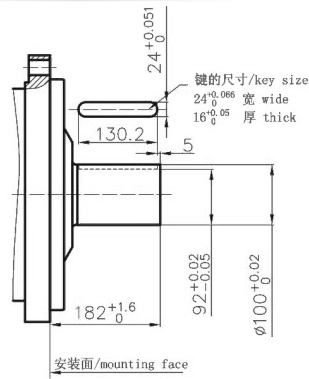

H-HMB200-T71

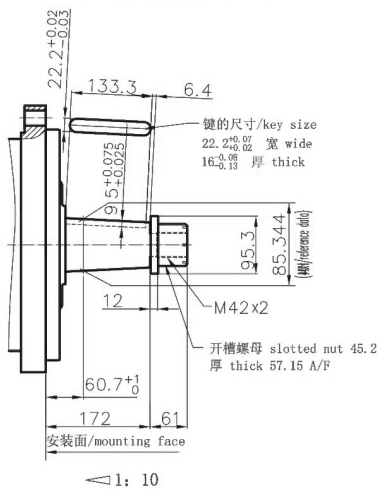

H-HMBHD200-T72

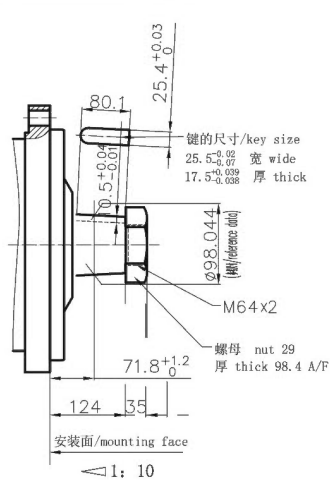

H-HMB(HD)200系列/H-HMB(HD)200 Series

H-HMB200-S71* & S72*

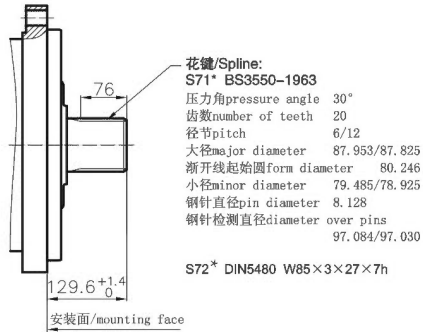

H-HMBHD200-S73 & S74

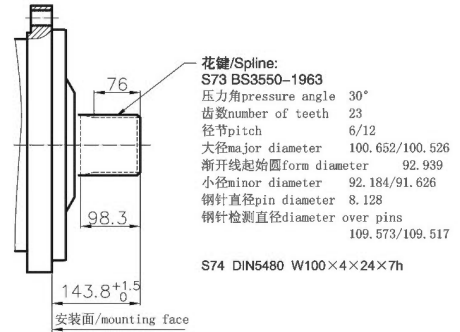

H-HMBHD200-Q71

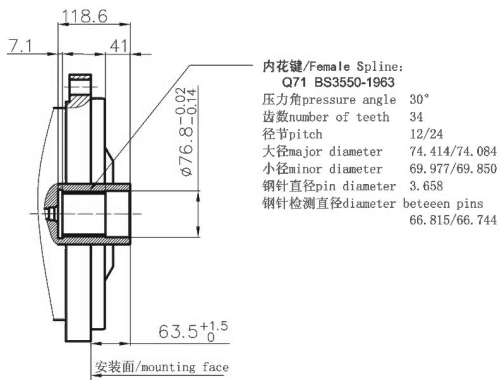

H-HMBHD200-S77

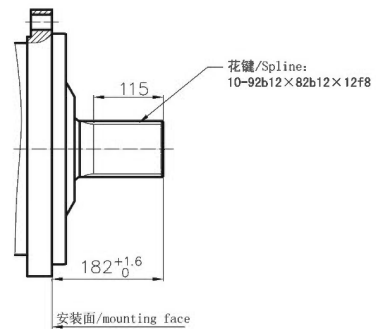

H-HMB200-P72

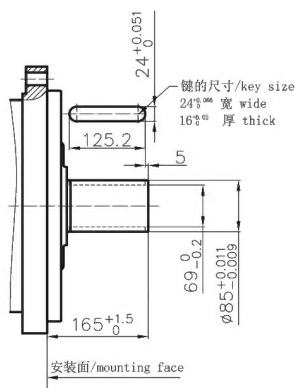

H-HMBHD200-P74

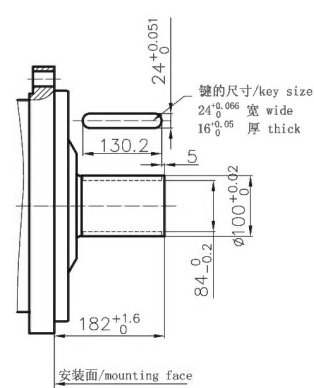

HFM

HGM

QJM

H-HMB

H-HMC

HCA

HCB

HMS

HA6V

HA2F

H-HMB(HD)200系列/H-HMB(HD)200 Series

H-HMBHD200-P75

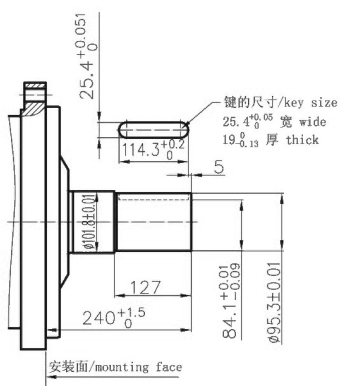

H-HMBHD200-S76

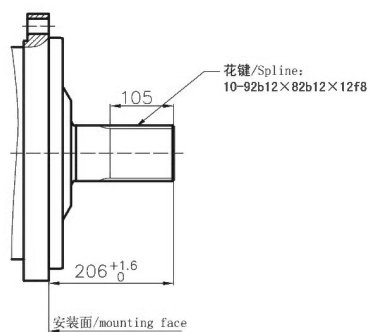

H-HMBHD200-T73

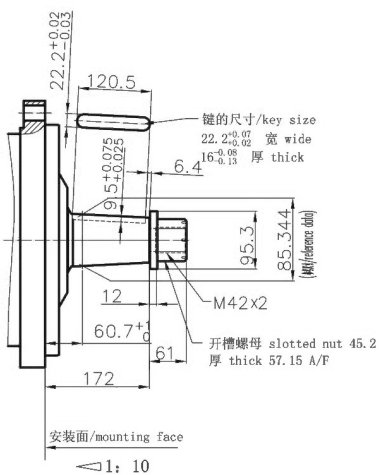

注释：右上角带* 的轴为标准轴
如：P73* 为标准平键轴 S71* 为标准花键轴

Notes: Shaft model with "*" is the standard shaft
Example: P73*=Standard Parallel Keyed Shaft
S71*=Standard Spline Shaft

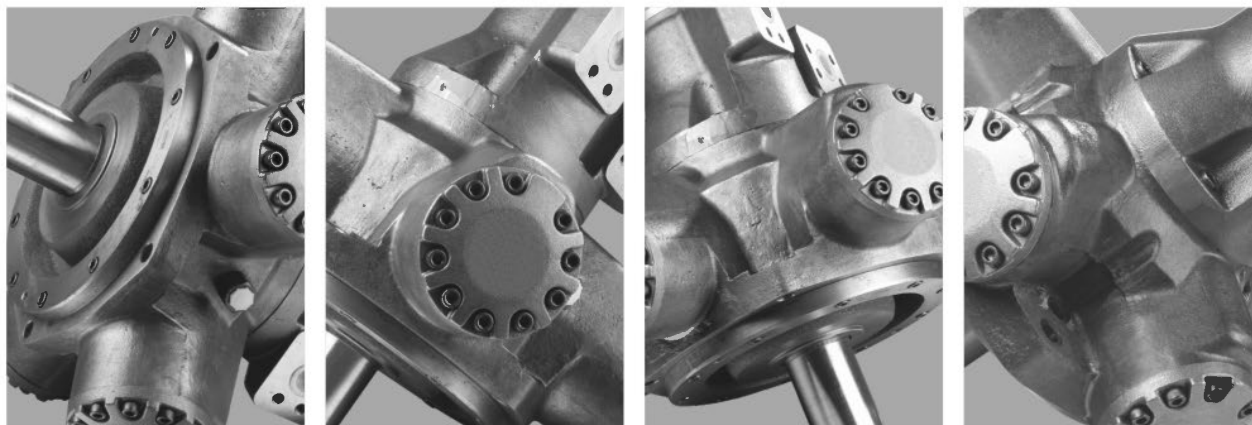

H-HMB(HD)200系列/H-HMB(HD)200 Series

H-HMB(HD)200 外形及安装尺寸/ H-HMB(HD)200 Installation Dimensions

进出油口为F01的安装尺寸/ F01 Distributor

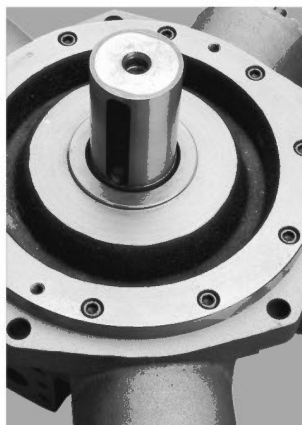
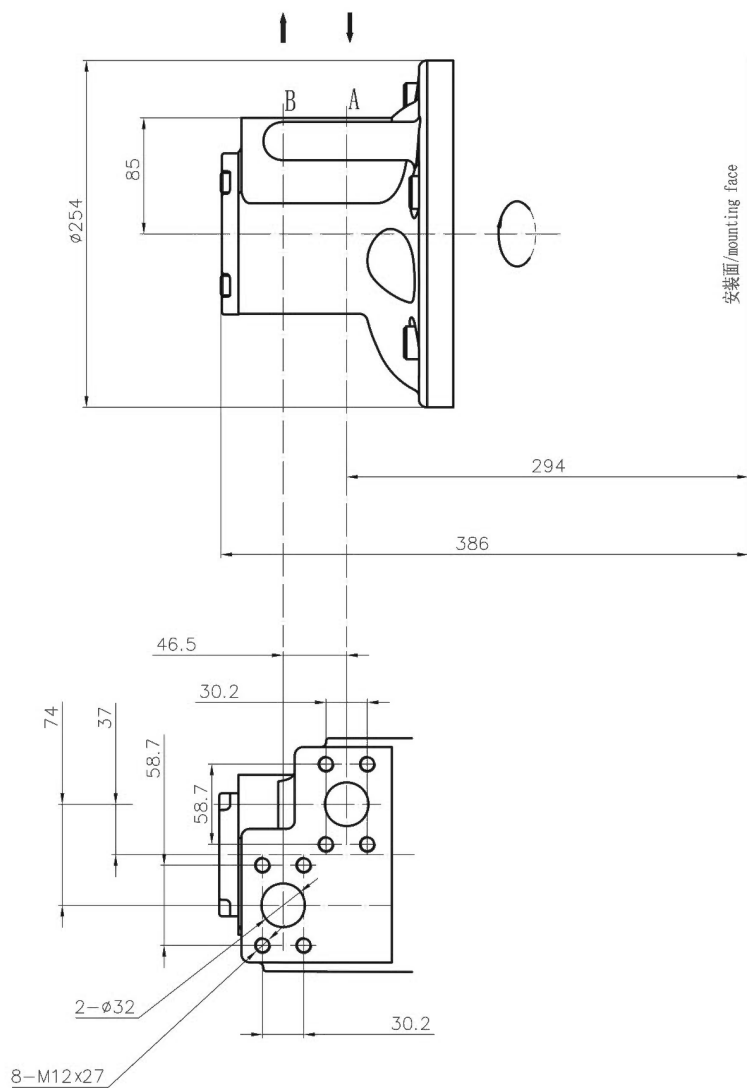

HFM

HGM

QJM

H-HMB

H-HMC

HCA

HCB

HMS

HA6V

HA2F

H-HMB(HD)200系列/H-HMB(HD)200 Series

H-HMB(HD)200 外形及安装尺寸/ H-HMB(HD)200 Installation Dimensions

进出油口为F01B的安装尺寸/ F01B Distributor

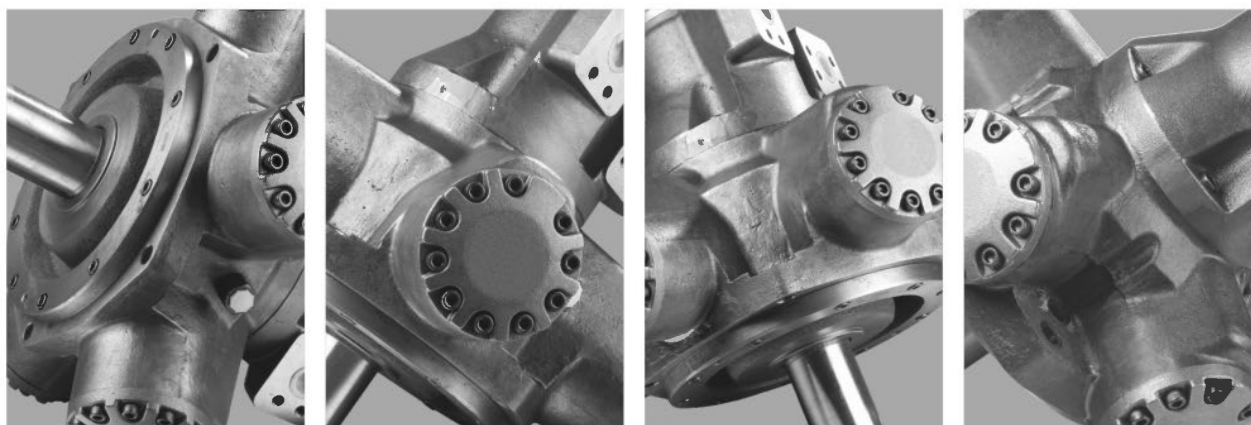
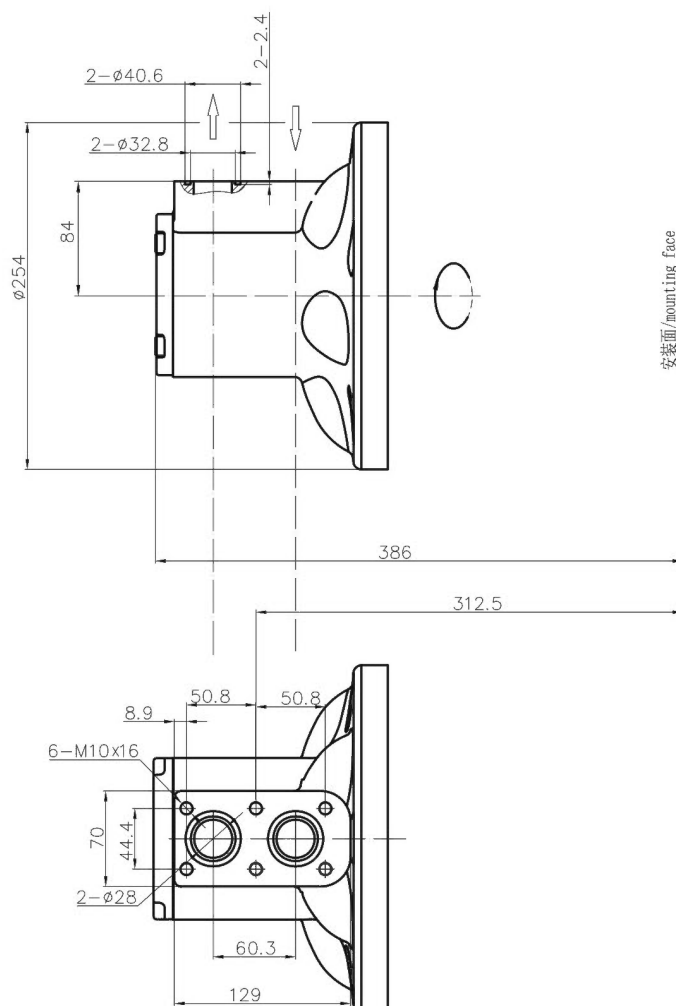

H-HMB(HD)200系列/H-HMB(HD)200 Series

H-HMB(HD)200 外形及安装尺寸/ H-HMB(HD)200 Installation Dimensions

进出油口为F02B的安装尺寸/ F02B Distributor

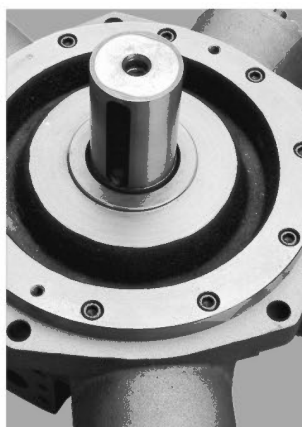
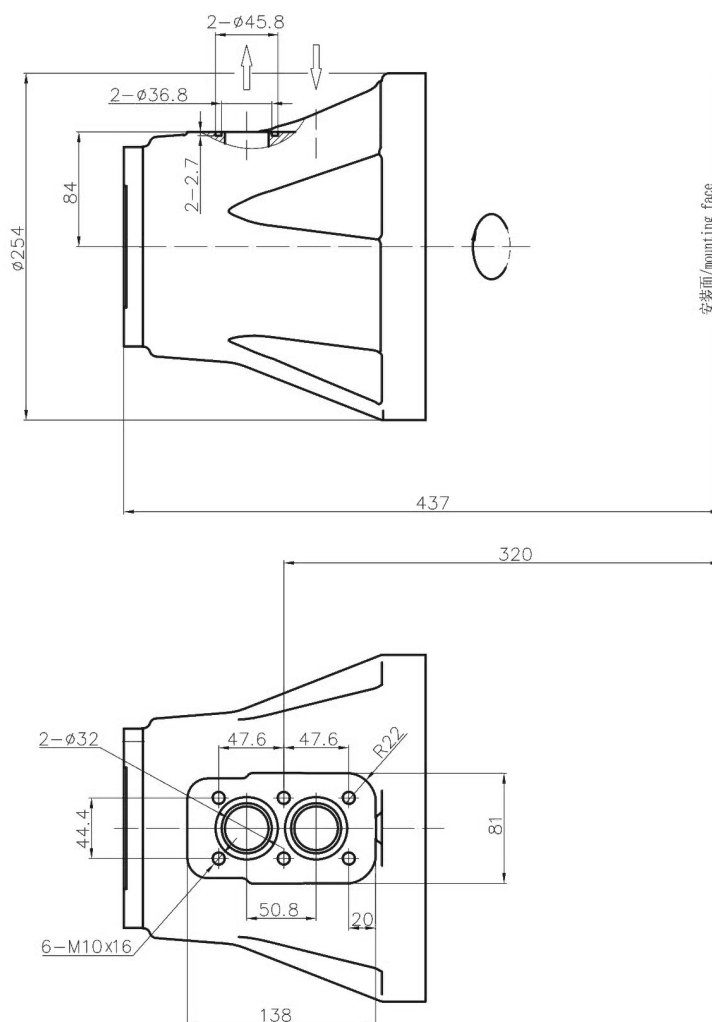

HFM

HGM

QJM

H-HMB

H-HMC

HCA

HCB

HMS

HA6V

HA2F

H-HMB(HD)270/325系列/H-HMB(HD)270/325 Series

H-HMB(HD)270 外形及安装尺寸/ H-HMB(HD)270 Installation Dimensions

进油口为F03的安装尺寸/With F03 Distributor

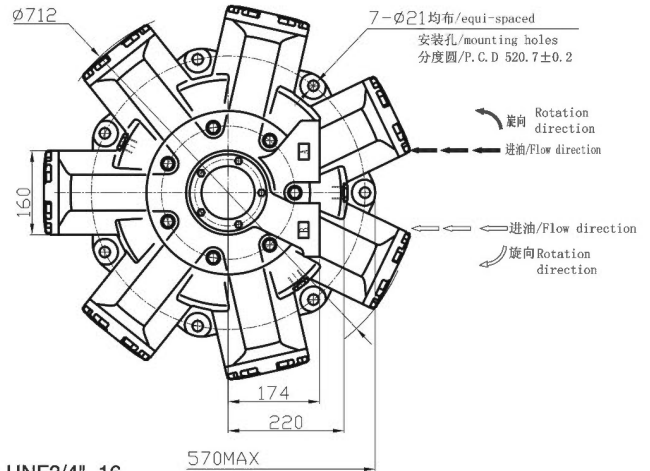
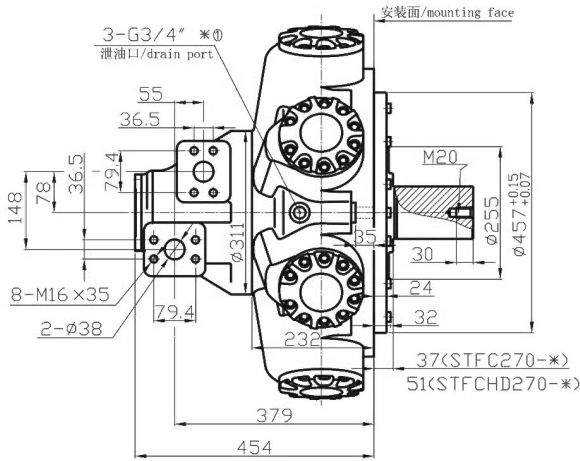

*①可选配UNF3/4"-16接头/Option: UNF3/4"-16

H-HMB(HD)325 外形及安装尺寸/ H-HMB(HD)325 Installation Dimensions

进油口为F03的安装尺寸/With F03 Distributor

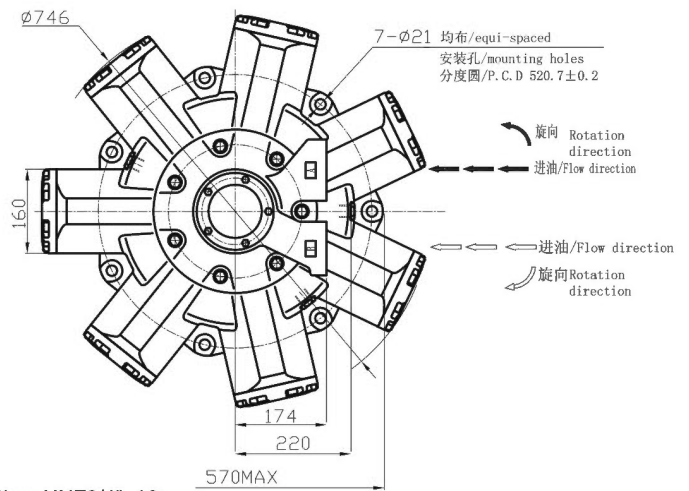
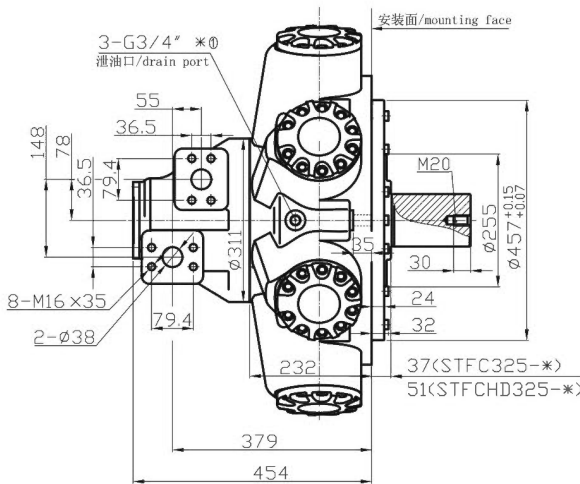

*①可选配UNF3/4"-16接头/Option: UNF3/4"-16

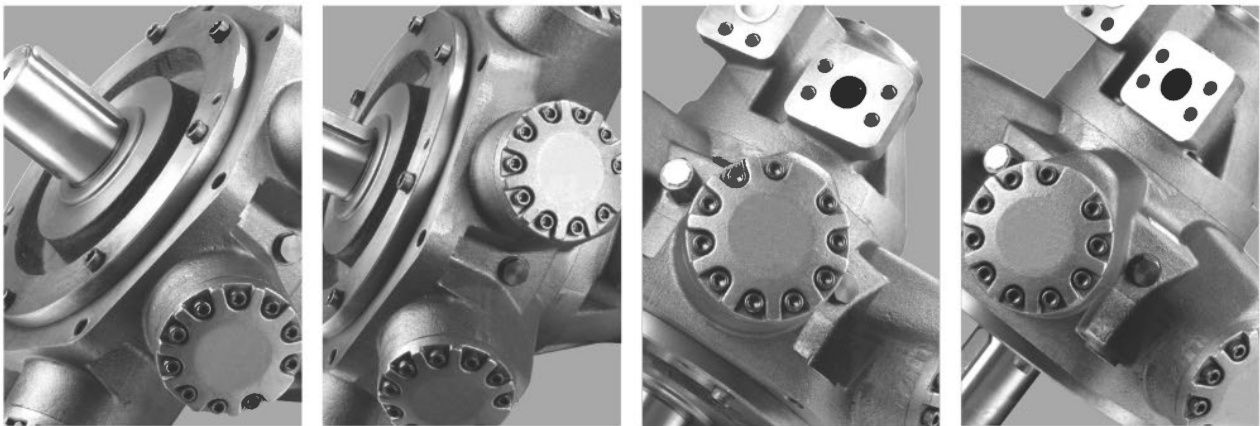

H-HMB(HD)270/325系列/H-HMB(HD)270/325 Series

H-HMB270H-HMB325-P73

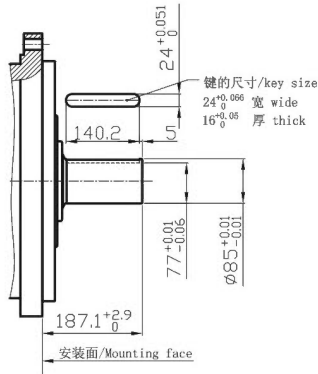

H-HMB270H-HMB325-P74*

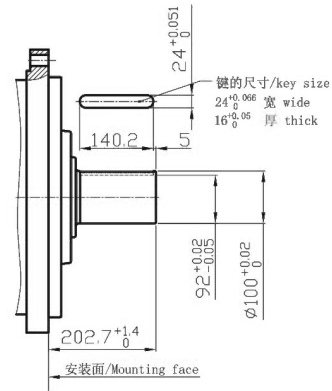

H-HMB270H-HMB325-T71

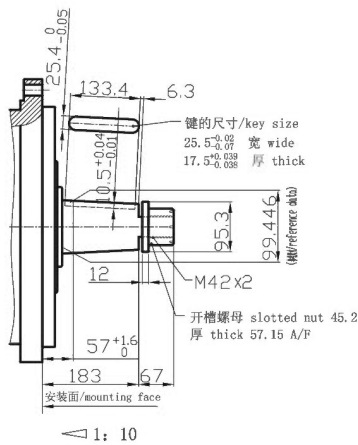

H-HMB270H-HMB325-T72

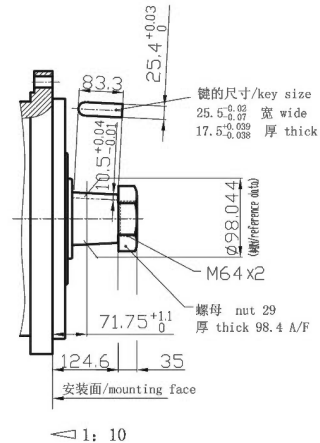

H-HMB270H-HMB325-S71*&S72*

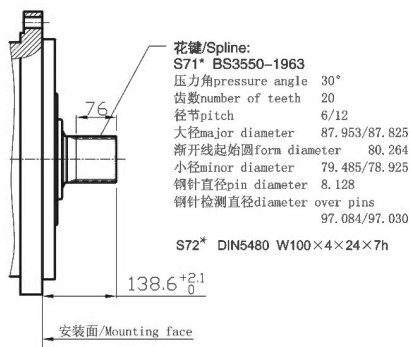

H-HMB270H-HMB325-Q72

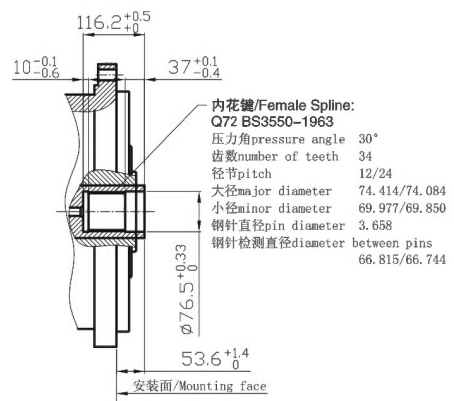

注释：右上角带* 的轴为标准轴
如：P74* 为标准平键轴 S71* 为标准花键轴

Notes: Shaft model with "*" is the standard shaft
Example: P74*=Standard Parallel Keyed Shaft
S71*=Standard Spline Shaft

HFM

HGM

QJM

H-HMB

H-HMC

HCA

HCB

HMS

HA6V

HA2F

H-HMB(HD)270/325系列/H-HMB(HD)270/325 Series

H-HMB270H-HMB325-P71

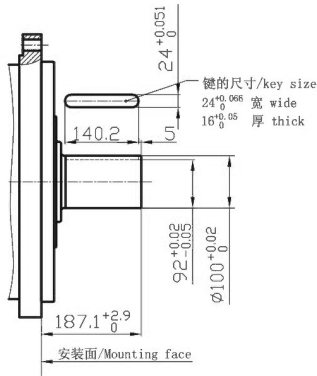

H-HMB270H-HMB325-P72

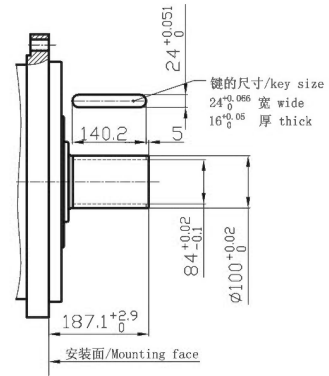

H-HMBHD270H-HMBHD325-P75

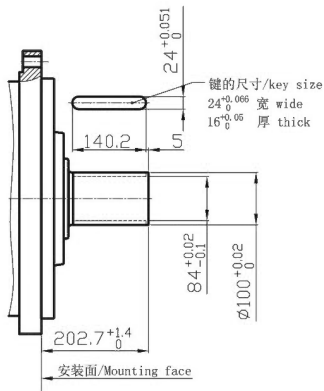

H-HMBHD270H-HMBHD325-P77

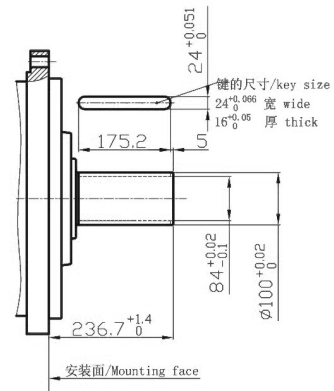

H-HMB270H-HMB325-S73

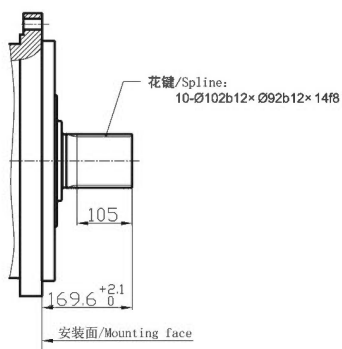

H-HMB270H-HMB325-Q71

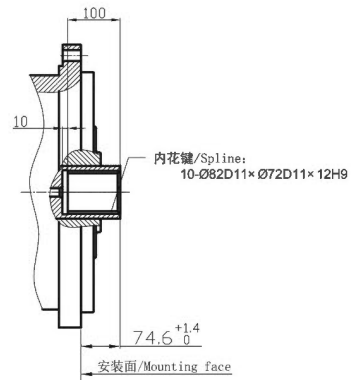

注释：右上角带*的轴为标准轴
如：P74* 为标准平键轴 S71*为标准花键轴

Notes: Shaft model with "*" is the standard shaft
Example: P74*=Standard Parallel Keyed Shaft
S71*=Standard Spline Shaft

H-HMB(HD)270/325系列/H-HMB(HD)270/325 Series

H-HMB(HD)270/325 外形及安装尺寸/ H-HMB(HD)270/325 Installation Dimensions

进出油口为F03B的安装尺寸/ F03B Distributor

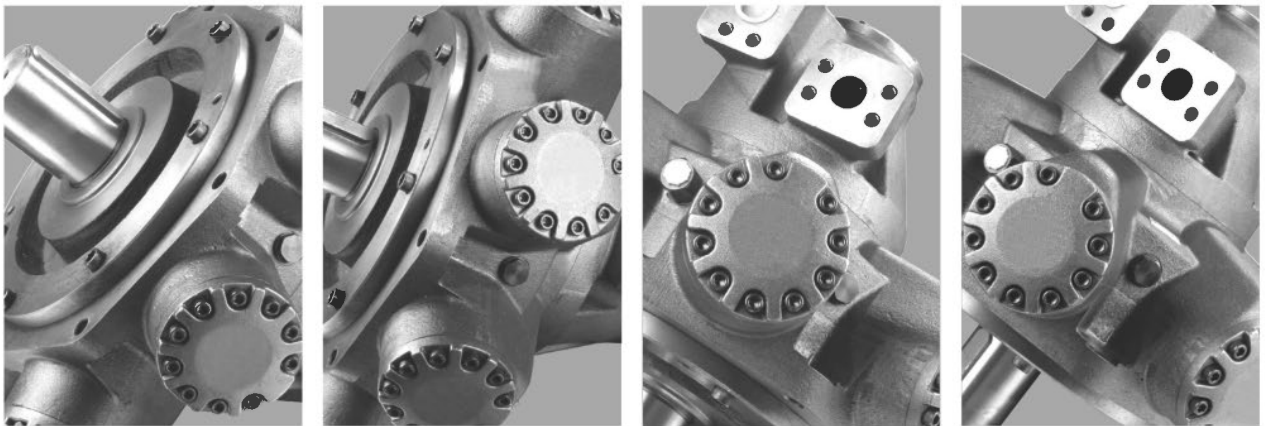
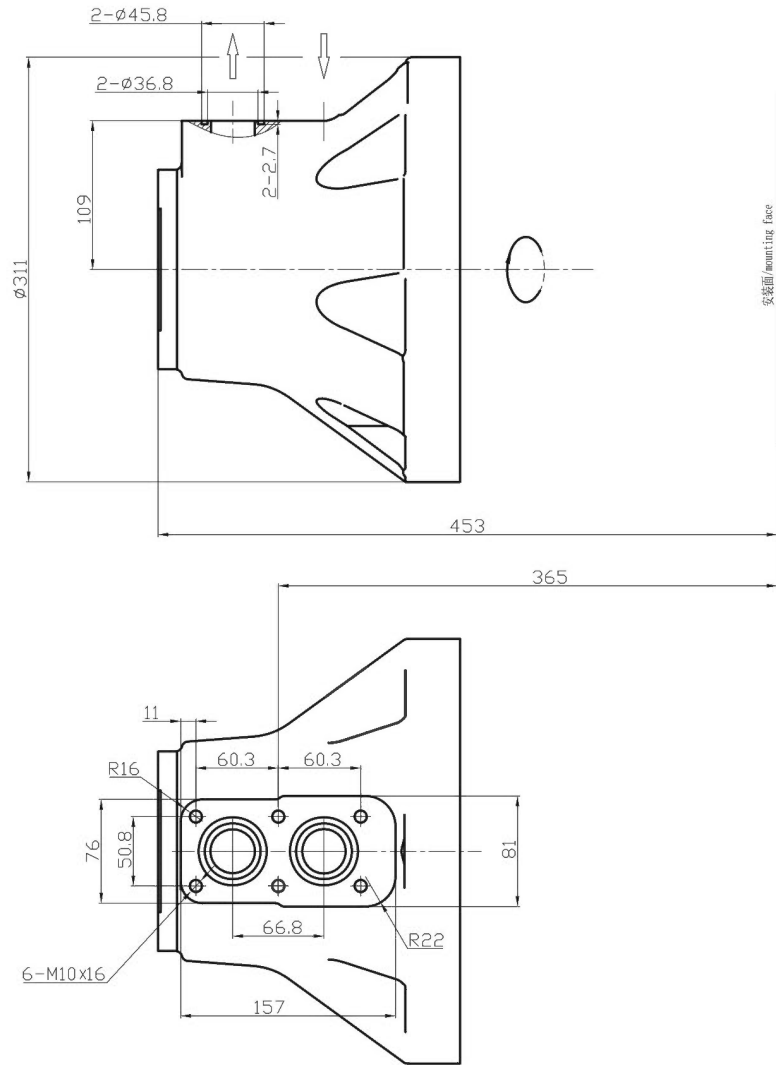

HFM

HGM

QJM

H-HMB

H-HMC

HCA

HCB

HMS

HA6V

HA2F

H-HMB(HD)400系列/H-HMB(HD)400 Series

H-HMB(HD)400 外形及安装尺寸/ H-HMB(HD)400 Installation Dimensions

进出油口为F04的安装尺寸/With F04 Distributor

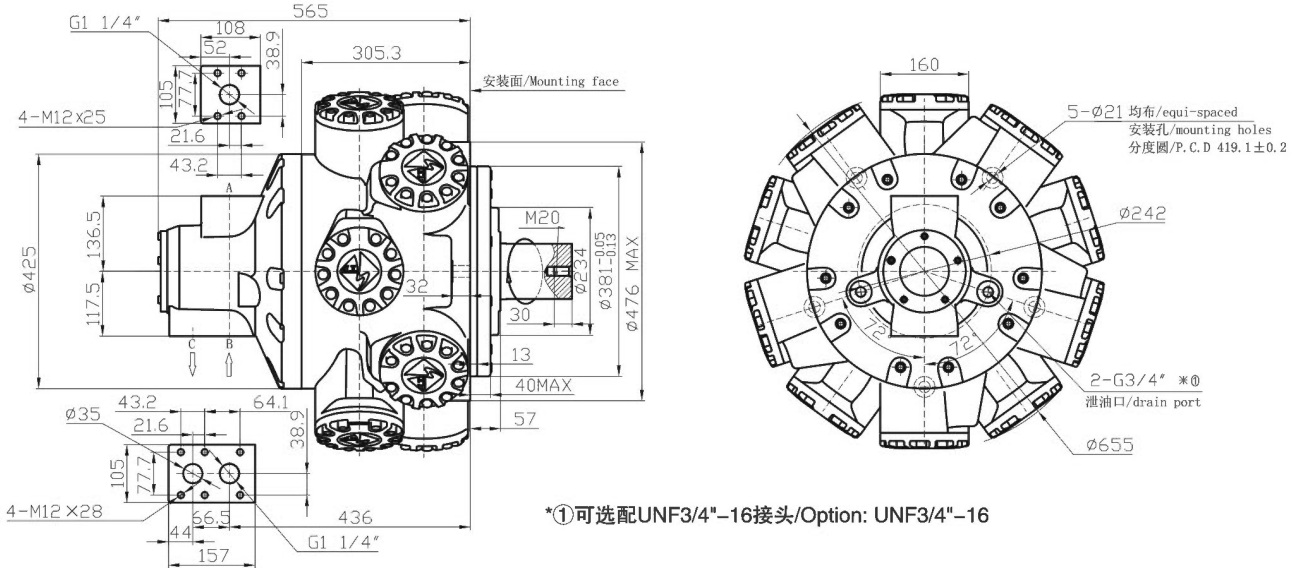

H-HMBHD400-P71*

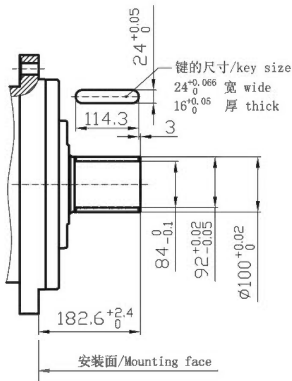

H-HMBHD400-S71*&S72*

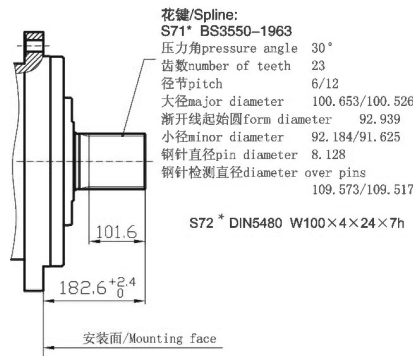

H-HMBHD400-S73

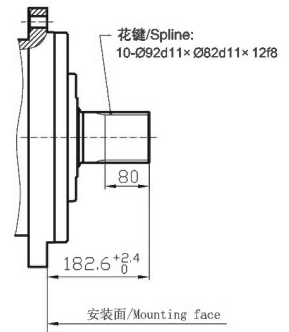

H-HMBHD400-Q71

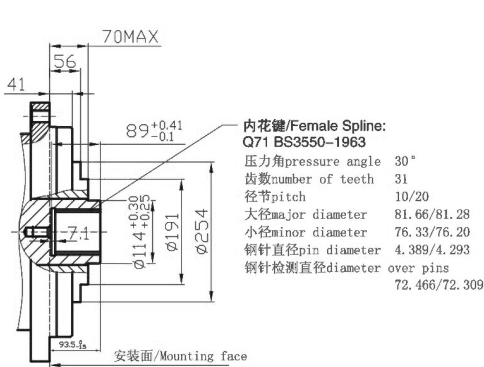

H-HMBHD400-T71

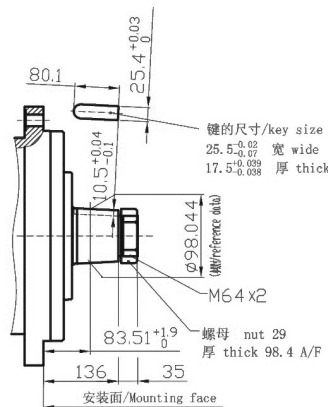

注释: 右上角带* 的轴为标准轴
如: P71* 为标准平键轴 S71* 为标准花键轴

Notes: Shaft model with "*" is the standard shaft
Example: P71*=Standard Parallel Keyed Shaft
S71*=Standard Spline Shaft

H-HMB(HD)400系列/H-HMB(HD)400 Series

H-HMB(HD)400 外形及安装尺寸/ H-HMB(HD)400 Installation Dimensions

进出油口为F04B的安装尺寸/ F04B Distributor

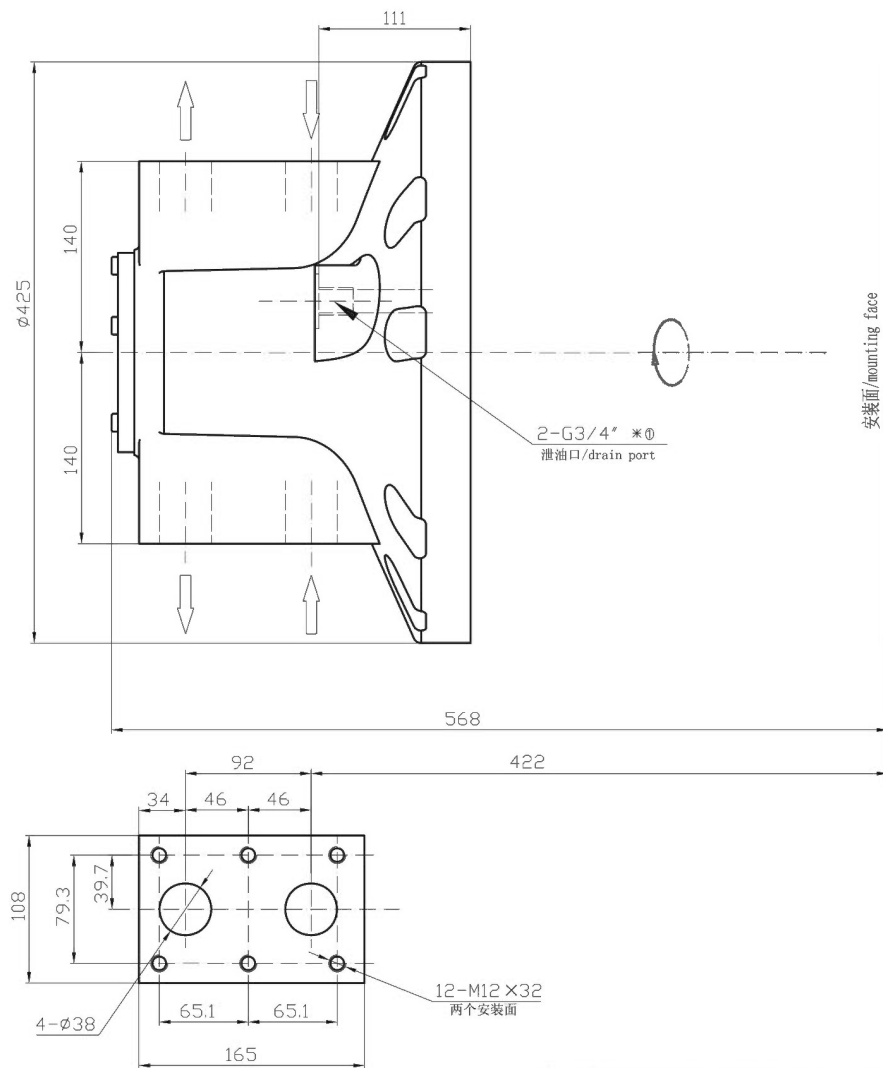

*①可选配UNF3/4"-16接头/Option: UNF3/4"-16

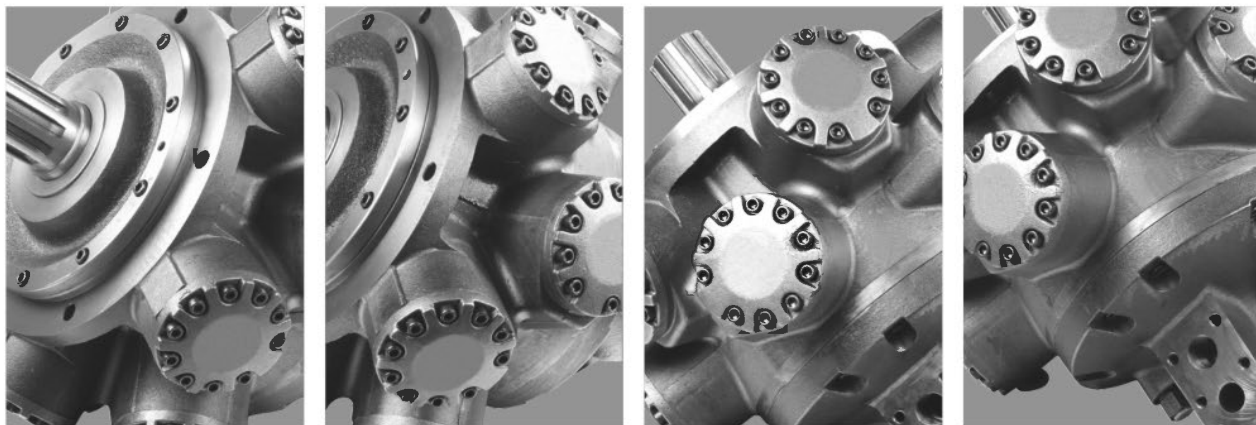

HFM

HGM

QJM

H-HMB

H-HMC

HCA

HCB

HMS

HA6V

HA2F